

# S2 *plus* Flying Probe Test System

Double Sided Tester for Substrate and HDI Boards



- ▲ 8 Test Heads
- ▲ Fast Dual Shuttle System
- ▲ High Speed Direct Linear Drives for X and Z motion
- ▲ No Probe Marks
- ▲ Fast 300mA Kelvin Testing

# S2 plus Technical Specifications

## Flying Probe Test System

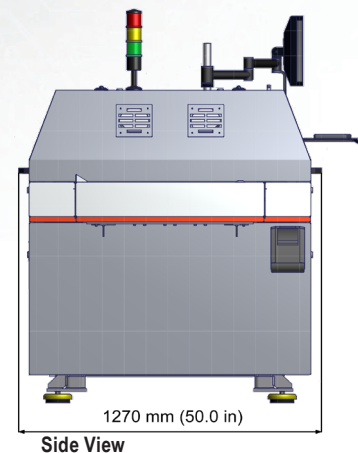
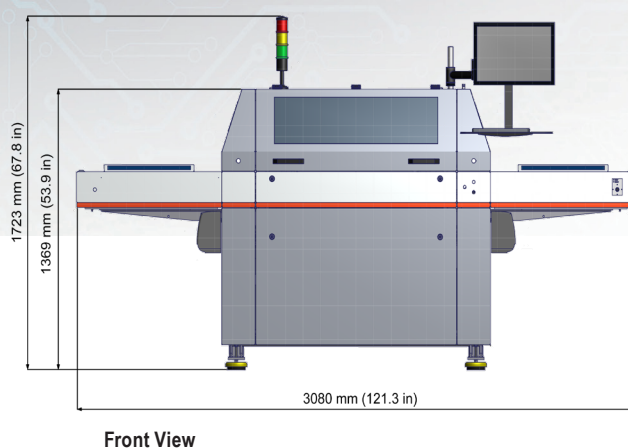

### Mechanics

Basic unit with 8 probes (4 top, 4 bottom)  
Dual universal shuttle system with clamp and stretch mode for testing substrate and HDI boards

Max. board size (X x Y)	610 mm x 330 mm / 24.0" x 13.0"
Min. board size (X x Y)	10 mm x 10 mm / 0.4" x 0.4"
Test area (X x Y)	610 mm x 310 mm / 24" x 12.2"
Board thickness	up to 2 mm

Smallest pad	15 $\mu\text{m}$ / 0.6 mil* (special setup)
Smallest pitch	30 $\mu\text{m}$ / 1.2 mil
Resolution measuring system	$\pm 0.1 \mu\text{m}$ / $\pm 0.004 \text{ mil}$
Repeatable accuracy	$\pm 2 \mu\text{m}$ / $\pm 0.8 \text{ mil}$

Soft touch probes or *Micro needle probes	5 g to 10 g 0.3 g to 2.5 g
--	-------------------------------

### Electronics

Continuity test	1 $\Omega$ to 10 k $\Omega$
Isolation test	up to 25 M $\Omega$ (FM), up to 100 G $\Omega$ (ohmic) MicroShort Detection®
Test voltage	100 mV to 1000 V

### Camera System

4 high resolution cameras for fast optical scanning of top and bottom side.  
Resolution 3  $\mu\text{m}$ / pixel

### Options

- 4-wire measurement with max. 300 mA test current
 

0 $\Omega$ to 1 k $\Omega$	$\pm 2 \%$ , min $\pm 25 \mu\Omega$
with FP Kelvin probes	0.3 g to 2 g
Smallest pad	40 $\mu\text{m}$ / 1.6 mil*
Smallest pitch	80 $\mu\text{m}$ / 3.2 mil*

 \* special setup
- Embedded components test
 

R 0 $\Omega$ to 1 M $\Omega$	$\pm 1 \%$ , min. $\pm 0.5 \Omega$
1 M $\Omega$ to 200 M $\Omega$	$\pm 3 \%$
C 0 F to 100 $\mu\text{F}$	$\pm 2 \%$ , min. $\pm 30 \text{ fF}$
L 0 H to 10 mH	$\pm 5 \%$ , min. $\pm 0.25 \mu\text{H}$
Diode / Varistor	
$U_{F^+}$ , $U_{R^+}$ , $U_{BR}$	0 V to 12.5 V

- Pneumatic clamping with supporting table for flexible boards
- Retest of fault files from external grid test systems on inquiry
- Repair software with barcode support

<b>Data input format</b>	IPC-D-356A
<b>Network connection</b>	Ethernet, TCP / IP
<b>Power supply</b>	3 x 400 V, 50 Hz (3 x 208 V, 60 Hz), 1200 VA
<b>Compressed air</b>	8 bar / 115 psi, filtered
<b>Temperature</b>	18 $^{\circ}\text{C}$ to 24 $^{\circ}\text{C}$
<b>Relative humidity</b>	40% to 60%
<b>Machine weight</b>	1550 kg

All information subject to change without notice!  
September 2021