

S3 Flying Probe Test System

For Substrate Boards



- ▲ 4 Test Heads
- ▲ Single Sided Test with Vacuum Table
- ▲ High Speed Direct Linear Drives for X and Z motion
- ▲ No Probe Marks
- ▲ Optical auto focus Microscope Lenses
- ▲ Fast 300 mA Kelvin Testing

S3 Technical Specifications

Flying Probe Test System

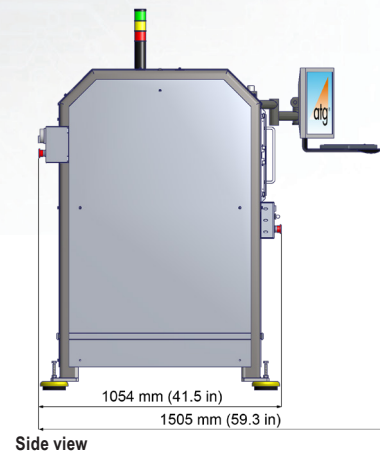
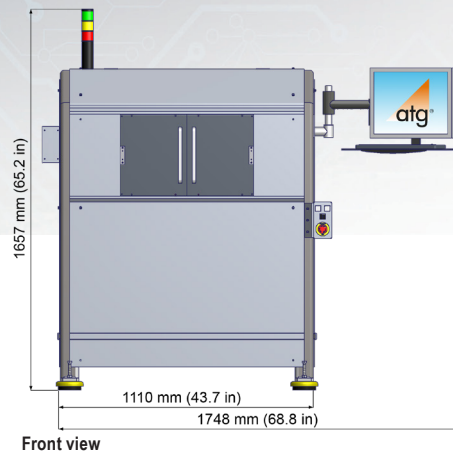

Mechanics

Single sided test system, 4 probes on top side
 Vacuum table for loading of Flex and Substrate boards
 Max. board size (X x Y) 330 mm x 310 mm / 13.0" x 12.2"
 Test area (X x Y) 300 mm x 310 mm / 11.8" x 12.2"
 Board thickness 0.05 mm to 3 mm

Smallest pad 10 μm / 0.4 mil* (Special setup)
 Smallest pitch 25 μm / 1.0 mil
 Resolution measurement system $\pm 0.1 \mu\text{m}$ / $\pm 0.004 \text{ mil}$
 Repeatable accuracy $\pm 1.5 \mu\text{m}$ / $\pm 0.06 \text{ mil}$

*Micro needle probes 0.3 g to 2.5 g
 Soft landing

Electronics

Continuity test 1 Ω to 10 k Ω
 Isolation test up to 25 M Ω (FM),
 up to 100 G Ω (ohmic)
 MicroShort Detection®
 Test voltage 100 mV to 1000 V

Camera System

1 high resolution color camera for optical scanning of top side.
 Resolution 1.2 μm / pixel

Options

- 4-wire measurement with max. 300 mA test current
 0Ω to 1 k Ω $\pm 2 \%$, min. $\pm 25 \mu\Omega$
 with FP Kelvin probes 0.3 g to 2 g
 Smallest pad 30 μm / 1.2 mil*
 Smallest pitch 80 μm / 3.2 mil*
 * special setup

- Embedded components test
 R 0 Ω to 1 M Ω $\pm 1 \%$, min. $\pm 0.5 \Omega$
 1 M Ω to 200 M Ω $\pm 3 \%$
 C 0 F to 100 μF $\pm 2 \%$, min. $\pm 30 \text{ fF}$
 L 0 H to 10 mH $\pm 5 \%$, min. $\pm 0.25 \mu\text{H}$

Diode / Varistor $U_{CR}, U_{RR}, U_{BR}, U_{BR}$ 100 mV to 12.5 V
 Structural test of integrated circuits:
 opens/shorts test on CMOS devices with ESD diodes



Multi-Point Measurements

Up to three AC/DC sources (voltage and current) simultaneously.
 Transistors (MOSFET and Bipolar), Optocouplers, Fuses,
 Relays, Transformers, etc.
 $I_{\text{max}} = 300 \text{ mA}$



- Repair software with barcode support

Data Input Format IPC-D-356A
Network Connection Ethernet, TCP / IP
Power Supply 3 x 400 V, 50 Hz (3 x 208 V, 60 Hz), 500 VA
Power Supply Vacuum Pump for Vacuum Table 230 V, 50 Hz, 1500 VA
Compressed Air 8 bar / 115 psi, filtered, constant air quantity
Temperature 18 $^{\circ}\text{C}$ to 24 $^{\circ}\text{C}$
Relative Humidity 40% to 60%
Machine Weight 900 kg

All information subject to change without notice!
 September 2021