

# LM1000

## Universal Grid System for step testing



- ▲ Octal Density Universal Grid System
- ▲ Granite based Mechanics for Highest Accuracy
- ▲ Fully automatic Optical Alignment
- ▲ Quick & easy fixture set up
- ▲ High Density Cassettes for Dedicated Fixture (optional)

# LM1000 Technical Specifications

## Universal Grid System

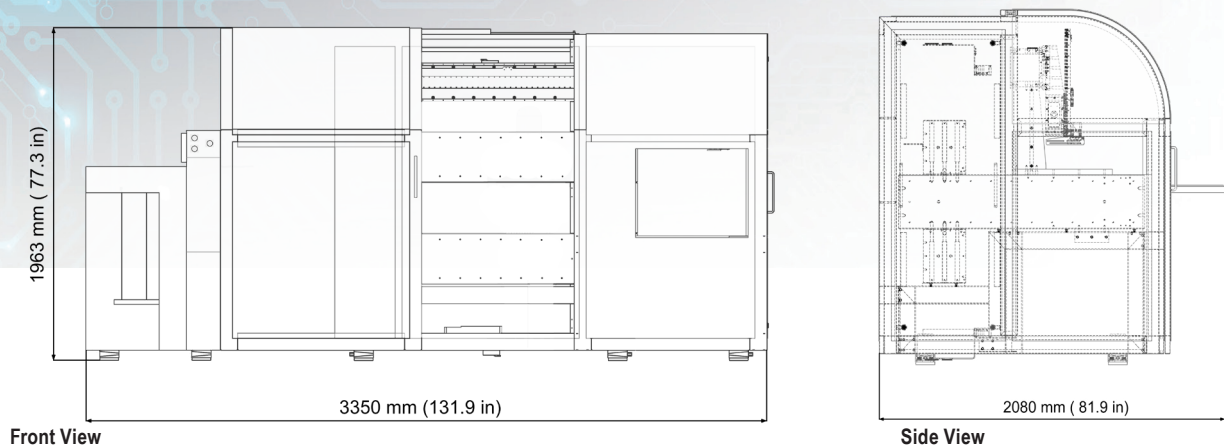

### Mechanics

Fully automated dual-shuttle grid system. Supports universal and/or dedicated fixtures. Free selectable step numbers for individual optical alignment recognition. Dual vacuum handler with 180° rotation and slip sheet handling.

Max. board size (X x Y)	400 mm x 300 mm / 15.8" x 11.8" (depends on product layout)
Min. board size (X x Y)	50 mm x 50 mm / 2.0" x 2.0"
Board thickness	0.6 mm to 3.0 mm
Loader capacity	600 mm
Mechanical accuracy	≤ ± 5 μm

### Electronics

Max. test area (X x Y)	244 mm x 163 mm / 9.6" x 6.4"
Density	800 test points / inch <sup>2</sup> 35 mil
Max. electronic contact points	49.152 per side
Max. test points	24.576 per side

### Test Parameters

Continuity Test	10 Ω* to 10 kΩ * depends on fixture style
Isolation Test	100 kΩ to 100 MΩ
Isolation Voltage	35 V to 250 VDC
Embedded Resistor Measurement 2-wire and 4-wire	0 Ω to 50 kΩ
Extended inspection methods	HIC, MicroShort, Spark Test LED MicroStep Test

### Options

- 4-wire measurement  
Test range 1 mΩ to 50 KΩ  
Tolerance ± 1 mΩ, but min. ± 2 %  
Measurement speed up to 1200 tests per sec with ± 2 mΩ accuracy (depends on product layout)
- High Density Cassettes for Dedicated Fixture  
Test points up to 28.160 test points  
(14.080 top / 14.080 bottom)  
Max. fixture size 350 x 190 mm / 13.8" x 7.5"  
Combination between universal and dedicated fixture needs full equipped electronic
- Cleaning Station
- Repair software with barcode support
- External Barcode Scanner
- Edge Marker
- Spark Test via Voltage Drop

Data Input	IPC-D-356A
Power supply	AC 400 V [3 / N / PE AC 400 V] 50 / 60 Hz
Compressed air	Connecting pressure 6 bar
Temperature	20 °C to 25 °C
Relative humidity	40 % to 60 %
Machine weight	About 3342 kg / 7368 lbs

All information subject to change without notice!  
January 2025

### atg Luther & Maelzer GmbH

Karl-Carstens-Straße 19 · 97877 Wertheim · Germany  
Phone +49 9342 291 0 · sales.atg-LM@mycronic.com  
www.atg-LM.com

### atg Luther & Maelzer GmbH

Hagenburger Strasse 54 · 31515 Wunstorf · Germany  
Phone +49 5031 174 0 · sales.atg-LM@mycronic.com  
www.atg-LM.com