

S2-8 Flying Probe Test System

Double Sided Tester for Packages and Flexible Boards



- ▲ 8 Test Heads
- ▲ Fast Dual Shuttle System
- ▲ High Speed Direct Linear Drives for X and Z motion
- ▲ No Probe Marks
- ▲ Fast 280mA Kelvin Testing

S2-8 Technical Specifications

Flying Probe Test System

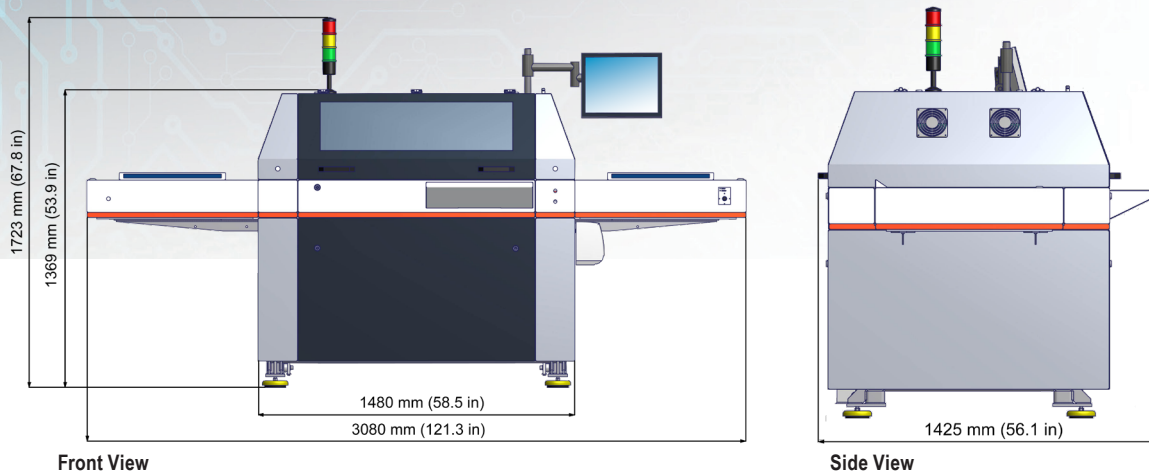

Mechanics

Basic unit with 8 probes (4 top, 4 bottom)
Single or dual universal shuttle system with clamp and stretch mode for testing flexible and rigid boards

Max. board size (X x Y)	610 mm x 330 mm / 24.0" x 13.0"
Min. board size (X x Y)	10 mm x 10 mm / 0.4" x 0.4"
Test area (X x Y)	610 mm x 310 mm / 24" x 12.2"
Board thickness	up to 5 mm

Smallest pad	25 μm / 1.0 mil* (special setup)
Smallest pitch	50 μm / 2.0 mil
Resolution measuring system	$\pm 0.1 \mu\text{m}$ / $\pm 0.004 \text{ mil}$
Repeatable accuracy	$\pm 3 \mu\text{m}$ / $\pm 0.12 \text{ mil}$

Soft touch probes or *Micro needle probes	5 g to 10 g 0.3 g to 2.5 g
--	-------------------------------

Electronics

Continuity test	1 Ω to 10 K Ω
Isolation test	up to 25 M Ω (FM), up to 10 G Ω (ohmic) MicroShort Detection [®]
Test voltage	up to 1000 V (ohmic)

Camera System

4 color cameras for fast optical scanning of top and bottom side.
Resolution 6 μm / pixel

Options

- 4-wire measurement with max. 280 mA test current

0.25 m Ω to 1 k Ω	$\pm 2 \%$, min $\pm 0.025 \text{ m}\Omega$
with Kelvin probes	0.3 g to 5 g
Smallest pad	50 μm / 2.0 mil*
Smallest pitch	80 μm / 3.2 mil*

 *with Kelvin probe fine adjustment

- Embedded components test

R	0.5 Ω to 10 M Ω	$\pm 0.5 \%$, min $\pm 0.5 \Omega$
	> 10 M Ω to 50 M Ω	$\pm 2 \%$
C	0.1 pF to 100 μF	$\pm 2 \%$, min $\pm 0.03 \text{ pF}$
L	0.2 μH to 5 mH	$\pm 3 \%$, min $\pm 0.1 \mu\text{H}$

 Diode / Varistor

U_R reverse voltage and	
U_{BR} breakdown voltage	100 mV to 12.5 V

- LaTest[®] open detection

with LaTest [®] probes	1 g to 10 g
High current	1.4 A (1 kHz)

- Pneumatic clamping with supporting table for flexible boards
- Retest of fault files from external grid test systems on inquiry
- Repair software with barcode support

Data input format	IPC-D-356A
Network connection	Ethernet, TCP / IP
Power supply	3 x 400 V, 50 Hz (3 x 208 V, 60 Hz), 1200 VA
Compressed air	8 bar / 115 psi, filtered
Temperature	18 $^{\circ}\text{C}$ to 27 $^{\circ}\text{C}$
Relative humidity	40% to 60%
Machine weight	1530 kg

All information subject to change without notice!
January 2025

atg Luther & Maelzer GmbH

Karl-Carstens-Straße 19 · 97877 Wertheim · Germany
Phone +49 9342 291 0 · sales.atg-LM@mycronic.com
www.atg-LM.com